



Circuit Protection

Product Information

	Page
Branch Rated Circuit Protection	
9926 Series—AC Version3
9926 Series—DC Version4
Supplemental Circuit Protection	
9926 Series5
CB4200 Series6
CB2200 Series8
CB9100 Series10

Weidmuller's DIN-rail mounted circuit breakers are available for use in applications where circuit protection must be able to distinguish between circuit overloads and short circuits. Each circuit breaker has the ability to be reset without the need to change components. All circuit breakers are available with an assortment of jumpers and marking tags.

Circuit breakers in the 9926 Series are UL 489 Listed and CSA Certified as branch rated protection devices under CSA 22.2 No. 5-02. The hydraulic magnetic trip mechanism offers 10,000A of interrupting capacity in 120V and 240V, 50/60Hz applications.



9926 Series

The CB2200 Series feature integrated alarm contacts within a narrow profile, thereby allowing increased enclosure capacity. All of these circuit breakers demonstrate consistent reliability through 100% calibration and testing, and feature a touch safe design to prevent injury from accidental contact with live components.



CB2200 Series

The CB4200 Series of thermal magnetic circuit breakers feature a push-button style of trip reset. This reset provides a visual indication of status which allows for rapid troubleshooting.



CB4200 Series

The CB9100 Series of thermal magnetic circuit breakers provide a rugged and industry-standard form factor (18 mm/pole). For supplemental circuit protection.



CB9100 Series

9926 Series Branch Rated Circuit Breakers—DC Version

Circuit Breakers Hydraulic Magnetic Type

9926 Series Single Pole

- Single pole versions only
- Higher current ratings made of 2 or 3 poles in parallel
- U2 trip curve for general purpose applications
- 80 VDC
- Up to 150A
- Just 13 mm wide
- Mounts on 35mm DIN-rail
- UL 489A listed



Ordering Data

Type: Single Pole

Current Ratings (amps)	Part No.	Description
0.5	9926251900	QY-1-13-DM-U2-0.5
1	9926251901	QY-1-13-DM-U2-01
2	9926251902	QY-1-13-DM-U2-02
5	9926251905	QY-1-13-DM-U2-05
10	9926251910	QY-1-13-DM-U2-10
15	9926251915	QY-1-13-DM-U2-15
20	9926251920	QY-1-13-DM-U2-20
25	9926251925	QY-1-13-DM-U2-25
30	9926251930	QY-1-13-DM-U2-30
35	9926251935	QY-1-13-DM-U2-35
40	9926251940	QY-1-13-DM-U2-40
45	9926251945	QY-1-13-DM-U2-45
50	9926251950	QY-1-13-DM-U2-50
60	9926251960	QY-1-13-DM-U2-60

9926 Series DC Version – dimensions in mm (in.)

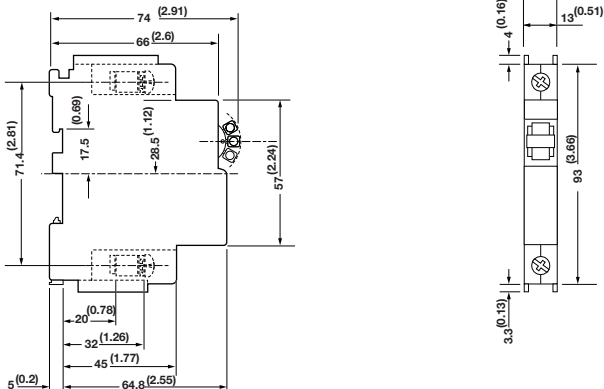

Technical Data

Voltage	80 VDC
Current	
minimum	0.5 A
maximum	150 A 3-Pole Parallel
Interrupting capacity	10,000 A
Dielectric strength	1500 V, 50/60 Hz
Insulation resistance	100 MΩ
Operating life	10000 mechanical operations
Operating temperature	-40...+60°C
Wire size*	
1-15A:	14 AWG min., 10 AWG max.
20-25A:	10 AWG min.
Torque	20 lb-in.

Approval

UL 489A Listed, CE

Accessories

Part No.

Bus-bar (54 pole, insulated) **67101904**

*Wire sizes; gauges specified are the minimum allowable as per CSA and UL standards

The 9926 circuit breakers do not have provisions for marking tags. A possible solution is to cut the adhesive SchS2 tag rail to length (approximately 20 mm on a single pole unit so the current rating remains visible or approximately 30 mm on a two pole unit).

The SchS2 accepts DEK, WS and ESG 8/17 marking tags.

The part number for adhesive SchS2 is **1720600000**.

Trip Curves—Hydraulic Magnetic Type Typical time/current characteristics at 30°C

9926 Series—DC version

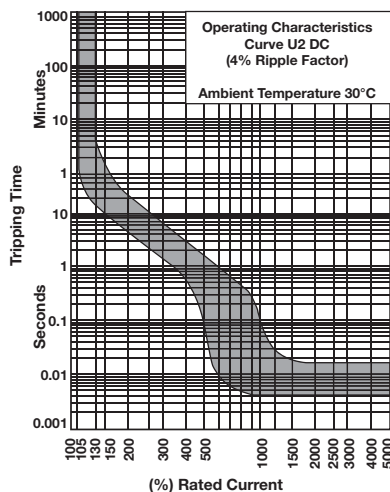

Additional trip curves and amp ratings are available upon request.

9926 Series Supplemental Circuit Breakers

Circuit Breakers Hydraulic Magnetic Type

- U2 trip curve for general purpose applications
- UL 1077 recognized
- VDE, CSA, and CE Approved
- Just 13 mm wide
- Mounts to 35 mm DIN-rail

9926 Series Single Pole



9926 Series Double Pole



9926 Series Triple Pole



Ordering Data	Type: Single Pole			Type: Double Pole			Type: Triple Pole		
	Current Ratings (amps)	Part No.	Description	Current Rating (amps)	Part No.	Description	Current Rating (amps)	Part No.	Description
	1	9926251501	QZ-1-13-D-2-01	1	9926252501	QZ-2-13-D-2-01	10	9926253510	QZ-3-13-D-2-10
	2	9926251502	QZ-1-13-D-2-02	5	9926252505	QZ-2-13-D-2-05	15	9926253515	QZ-3-13-D-2-15
	3	9926251503	QZ-1-13-D-2-03	10	9926252510	QZ-2-13-D-2-10	20	9926253520	QZ-3-13-D-2-20
	5	9926251505	QZ-1-13-D-2-05	15	9926252515	QZ-2-13-D-2-15	30	9926253530	QZ-3-13-D-2-30
	10	9926251510	QZ-1-13-D-2-10	20	9926252520	QZ-2-13-D-2-20			
	15	9926251515	QZ-1-13-D-2-15	50	9926252550	QZ-2-13-D-2-50			
	20	9926251520	QZ-1-13-D-2-20						
	50	9926251550	QZ-1-13-D-2-50						

9926 Series Supplemental – dimensions in mm (in.)

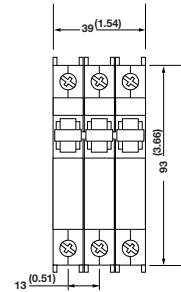
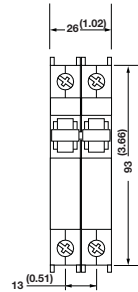
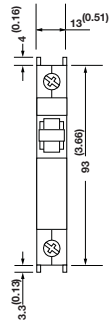
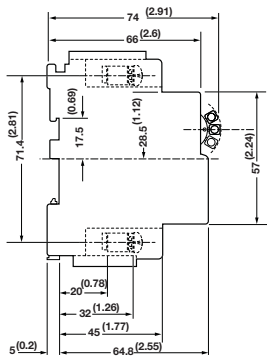

Technical Data

Voltage	277/480 VAC @ 50/60 Hz
Current	minimum 1 A maximum 60 A
Interrupting capacity	3 kA @ 277/480 V, 5 kA @ 120 V, 5 kA @ 240 V
Dielectric strength	1500 V, 50/60 Hz
Insulation resistance	100 Ω
Operating life	10000 mechanical operations
Operating temperature	-40...+60°C
Wire size*	1-15A: 14 AWG min., 10 AWG max. 20-25A: 10 AWG min.
Torque	20 lb-in.

Approval

UL 1077 Recognized

Accessories

Bus-bar (54 pole, insulated)	Part No. 67101904
------------------------------	-------------------

*Wire sizes: gauges specified are the minimum allowable as per CSA and UL standards

The 9926 circuit breakers do not have provisions for marking tags. A possible solution is to cut the adhesive SchS2 tag rail to length (approximately 20 mm on a single pole unit so the current rating remains visible or approximately 30 mm on a two pole unit).

The SchS2 accepts DEK, WS and ESG 8/17 marking tags.

The part number for adhesive SchS2 is 172060000.

Trip Curves—Hydraulic Magnetic Type Typical time/current characteristics at 30°C

9926 Series—Supplemental

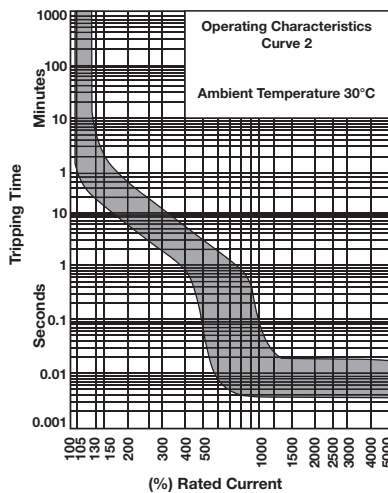

Additional trip curves and amp ratings are available upon request.

CB4200 Series Supplemental Circuit Breakers

Circuit Breakers Thermal Magnetic Type

- Rated from 0.05 to 16.0 amps
- Available in single or double pole configurations
- Features a tease free design to reduce contact damage
- Offers push button trip/reset function
- Trip free design means the breaker cannot be held closed against a fault
- Mounts on 32mm* or 35mm DIN-rail

CB4200 Series Single Pole



CB4200 Series Double Pole



Ordering Data
Internal Resistance per Pole (ohms)
447.00
220.00
131.00
40.00
19.30
10.40
7.10
4.30
3.58
2.50
1.67
1.22
1.08
1.00
0.61
0.55
0.38
0.24
0.19
0.16
0.09
0.09
0.061
0.07
0.041
0.04
0.034
0.02
0.02
<0.02
<0.02
<0.02
<0.02
<0.02
<0.02
<0.02

Type: Single Pole	
Current Ratings (amps)	Part No. TS 35 *For TS 32 Rail, see adapter below
0.05	9124083500
0.08	9124653500
0.1	9104173500
0.2	9104183500
0.3	9129813500
0.4	9124093500
0.5	9101003500
0.6	9124113500
0.7	9129563500
0.8	9101103500
1.0	9101203500
1.2	9101303500
1.3	9124123500
1.4	9124133500
1.5	9101403500
1.8	9124143500
2.0	9101503500
2.5	9101603500
3.0	9101703500
3.5	9124163500
4.0	9104353500
4.5	9124173500
5.0	9101803500
5.5	9107833500
6.0	9103813500
6.5	9120043500
7.0	9104153500
8.0	9103003500
9.0	9104613500
10.0	9101903500
11.0	9124183500
12.0	9107843500
13.0	9124193500
14.0	9107853500
15.0	9102003500
16.0	9124213500

Type: Double Pole	
Current Ratings (amps)	Part No. TS 35 *For TS 32 Rail, see adapter below
0.05	9124223500
0.08	9124233500
0.1	9120353500
0.2	9124243500
0.3	9124263500
0.4	9124273500
0.5	9129583500
0.6	9124283500
0.7	9124293500
0.8	9129593500
1.0	9129613500
1.2	9129623500
1.3	9124313500
1.4	9124323500
1.5	9129633500
1.8	9124333500
2.0	9129643500
2.5	9129653500
3.0	9129663500
3.5	9124343500
4.0	9129713500
4.5	9124353500
5.0	9129673500
5.5	9124363500
6.0	9124373500
6.5	9124383500
7.0	9124393500
8.0	9104673500
9.0	9124423500
10.0	9129683500
11.0	9124433500
12.0	9124443500
13.0	9124453500
14.0	9124463500
15.0	9129693500
16.0	9124473500

Trip Curves Thermal Magnetic Type Typical time/current characteristics at 23°C

CB4200 Series

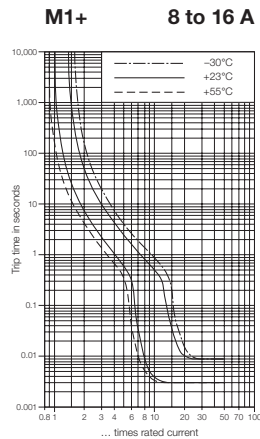
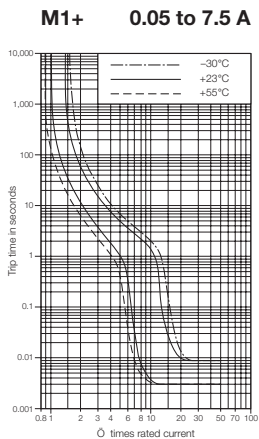

*Adapter foot

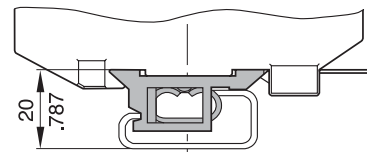

9102100000
TS32 adapter

CB4200 Series Supplemental Circuit Breakers

CB4200 Series Single Pole

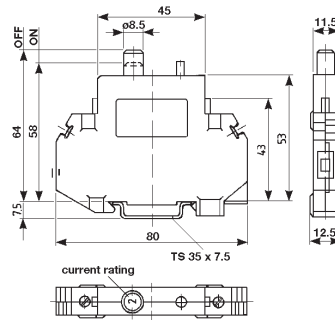

Internal Wiring Diagram

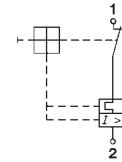

Dimensions in mm

CB4200 Series Double Pole

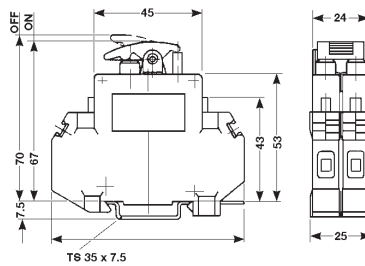

Internal Wiring Diagram

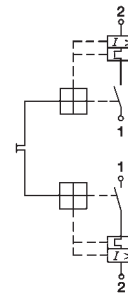

Dimensions in mm

Technical Data

Rated voltage & current†	UL
	CSA
	VDE
Creepage resistance	
Dielectric strength	
Insulation resistance	
Interrupting capacity (VDE 0660, Part 101, P-2)	
Interrupting capacity; 4201 (UL 1077/EN 60934 PC1)	
Typical life at 2 x rated current	
Shock	
Torque	
Vibration	
Temperature range	
Corrosion	
Humidity	
Weight	
Wire size (UL)	

Voltage Ratings		Current Ratings	
AC 250 V, DC 65 V, 50/60 Hz		0.05...16 A	
AC 250 V, DC 65 V, 50/60 Hz		0.05...16 A	
AC 250 V, DC 65 V, 50/60 Hz		0.05...16 A	
PTI 600 to IEC 112			
4,000 VAC; IEC 664 & 664 A			
> 100 MΩ (DC 500 V)			
4201-10	Maximum capacity		
0.05...0.8 A	Self-limiting		
1...2 A	200 A		
2.5...16 A	400 A		
Rated current	Rated voltage	Maximum capacity	
0.05...2.0 A	AC 250 V	200 A	
2.0...16 A	AC 250 V	200 A	
20 A	AC 125 V	400 A	
5,000 operations			
25 g (11 ms) to IEC 68-2-27, Test Ea			
1.2 Nm			
5 g (57 to 500 Hz / ±0.38 mm, 10 to 57 Hz) to IEC 68-2-6, Test Fc			
-30°C...+55°C (-22°F...+131°F)			
96 hours at 5% salt spray, to IEC 68-2-11, Test Ka			
240 hours at 95% RH, to IEC 68-2-3, Test Ca			
60 g per pole			
#20...8 AWG	solid/0.5...6 mm²		

Accessories

Jumpers	
	Daisy Chain 50*
	Straight CQB**
	insulated
	Angled CQB**
	insulated
Adapter foot (for TS 32 Rail)	

Type	Part No.
BDC 50	9970290000
CQB 2	9970560000
CQB 3	9970570000
CQB 4	9970580000
CQB 10	9970590000
CQB 2	9970600000
CQB 3	9970610000
CQB 4	9970620000
CQB 10	9970630000
MCBAF/TS 32	9102100000

Marking Tags

Note: Part numbers are shown for a single card of pre-printed tags numbered 1-50.	Special print only
	Consecutive horizontal
	Consecutive vertical

WS 8/5 MC	1640750000***
DEK 5/5	0473460001
DEK 5/5	0473560001

†Note: Resistive and inductive loads (0.05 - 16 A)

*BDC will accommodate 20 A per pin, 20 A total

**CQB will accommodate 18 A per pin, 18 A total; dedicated to 4201 Series

***Please specify horizontal or vertical print when ordering.

Standard quantity = 144 tags per card.

CB2200 Series Supplemental Circuit Breakers

Circuit Breakers Thermal Magnetic Type

- Rated from 0.1 to 32.0 amps
- Available in single, double and triple pole configurations
- Offers normally open (N/O) and normally closed (N/C) auxiliary contacts
- Lever-switch trip/reset function
- Mounts on 32mm or 35mm DIN-rail

CB2200 Series Single Pole



CB2200 Series Double Pole



CB2200 Series Triple Pole



Ordering Data	Type: Single Pole	Type: Double Pole	Type: Triple Pole
Internal Resistance per Pole (ohms)	Current Ratings (amps)	N/O-N/C Part No.	Current Ratings (amps)
92	0.1	9911010005	0.1
26.1	0.2	9911020005	0.2
11.6	0.3	9911030005	0.3
6.6	0.4	9911040005	0.4
4.1	0.5	9911050005	0.5
3	0.6	9911060005	0.6
1.65	0.8	9911080005	0.8
1.1	1.0	9911100005	1.0
0.47	1.5	9911150005	1.5
0.28	2.0	9911200005	2.0
0.18	2.5	9911250005	2.5
0.12	3.0	9911300005	3.0
0.08	4.0	9911400005	4.0
0.06	5.0	9911500005	5.0
0.04	6.0	9911600005	6.0
≤0.02	8.0	9911800005	8.0
≤0.02	10	9921100005	10
≤0.02	12	9921120005	12
≤0.02	15	9921150005	15
≤0.02	16	9921160005	16
≤0.02	18	9921180005	18
≤0.02	20	9921200005	20
≤0.02	25	9921250005	20
≤0.02	32	9921320005	

Ordering Data	Type: Single Pole	Type: Double Pole	Type: Triple Pole
Internal Resistance per Pole (ohms)	Current Ratings (amps)	N/O-N/C Part No.	Current Ratings (amps)
92	0.1	9912010003	0.1
26.1	0.2	9912020003	0.2
11.6	0.3	9912030003	0.3
6.6	0.4	9912040003	0.4
4.1	0.5	9912050003	0.5
3	0.6	9912060003	0.6
1.65	0.8	9912080003	0.8
1.1	1.0	9912100003	1.0
0.47	1.5	9912150003	1.5
0.28	2.0	9912200003	2.0
0.18	2.5	9912250003	2.5
0.12	3.0	9912300003	3.0
0.08	4.0	9912400003	4.0
0.06	5.0	9912500003	5.0
0.04	6.0	9912600003	6.0
≤0.02	8.0	9912800003	8.0
≤0.02	10	9922100003	10
≤0.02	12	9922120003	12
≤0.02	15	9922150003	15
≤0.02	16	9922160003	16
≤0.02	18	9922180003	18
≤0.02	20	9922200003	20

Ordering Data	Type: Single Pole	Type: Double Pole	Type: Triple Pole
Internal Resistance per Pole (ohms)	Current Ratings (amps)	N/O-N/C Part No.	Current Ratings (amps)
92	0.1	9913010003	0.1
26.1	0.2	9913020003	0.2
11.6	0.3	9913030003	0.3
6.6	0.4	9913040003	0.4
4.1	0.5	9913050003	0.5
3	0.6	9913060003	0.6
1.65	0.8	9913080003	0.8
1.1	1.0	9913100003	1.0
0.47	1.5	9913150003	1.5
0.28	2.0	9913200003	2.0
0.18	2.5	9913250003	2.5
0.12	3.0	9913300003	3.0
0.08	4.0	9913400003	4.0
0.06	5.0	9913500003	5.0
0.04	6.0	9913600003	6.0
≤0.02	8.0	9913800003	8.0
≤0.02	10	9923100003	10
≤0.02	12	9923120003	12
≤0.02	15	9923150003	15
≤0.02	16	9923160003	16
≤0.02	18	9923180003	18
≤0.02	20	9923200003	20

Ordering Data	Type: Single Pole	Type: Double Pole	Type: Triple Pole
Internal Resistance per Pole (ohms)	Current Ratings (amps)	N/O-N/C Part No.	Current Ratings (amps)
92	0.1	9913010003	0.1
26.1	0.2	9913020003	0.2
11.6	0.3	9913030003	0.3
6.6	0.4	9913040003	0.4
4.1	0.5	9913050003	0.5
3	0.6	9913060003	0.6
1.65	0.8	9913080003	0.8
1.1	1.0	9913100003	1.0
0.47	1.5	9913150003	1.5
0.28	2.0	9913200003	2.0
0.18	2.5	9913250003	2.5
0.12	3.0	9913300003	3.0
0.08	4.0	9913400003	4.0
0.06	5.0	9913500003	5.0
0.04	6.0	9913600003	6.0
≤0.02	8.0	9913800003	8.0
≤0.02	10	9923100003	10
≤0.02	12	9923120003	12
≤0.02	15	9923150003	15
≤0.02	16	9923160003	16
≤0.02	18	9923180003	18
≤0.02	20	9923200003	20

Ordering Options - Example

To order CB2200 Double Pole Circuit Breaker with N/C Aux.,
Part No. 9912100000

- Current Rating of 1.0 amps
- Internal Resistance per Pole of 1.1 ohms
- Trip Curve – M1, Medium (Standard)

9 9 1 2 1 0 0 0 0 0

Auxiliary Contacts[†]

- *00* – N/C Auxiliary Contact
- *02* – W/O Auxiliary Contact
- *03* – N/C-N/O Auxiliary Contacts (double and triple pole only)
- *05* – N/O Auxiliary Contact

Trip Curves

- *00* – M1, Medium (standard)
- *11* – F1, Fast (DC only)
- *12* – M3, Low Resistance
- *13* – T1, Delayed

Base Part No. (Indicates number of poles)*

Standard Current Ratings and Typical Internal Resistance Values

Current Rating (amps)	Internal Resistance (ohms)				
	F1 fast acting for DC	M1 standard delay for AC & DC	T1 delayed for AC	M3 low resistance standard delay for AC & DC	T2 thermal for AC & DC
0.1	162	92	81	42	77
0.2	39.3	26.1	24.2	11.7	23
0.3	17.5	11.6	10.4	5.6	10.2
0.4	9.2	6.6	6.0	2.9	5.7
0.5	6.8	4.1	3.9	1.75	3.7
0.6	4.2	3	2.7	1.42	2.6
0.8	2.8	1.6	1.53	0.75	1.39
1.0	1.6	1.10	0.98	0.5	0.9
1.5	0.78	0.47	0.42	0.22	0.36
2.0	0.42	0.28	0.24	0.136	0.19
2.5	0.26	0.183	0.17	0.083	0.141
3.0	0.18	0.124	0.12	0.057	0.091
4.0	0.12	0.077	0.073	0.041	0.051
5.0	0.092	0.063	0.055	0.032	0.040
6.0	0.054	0.045	0.039	0.021	0.027
8.0	0.025	≤0.02	≤0.02	≤0.02	≤0.02
10.0	0.022	≤0.02	≤0.02	≤0.02	≤0.02
12.0	≤0.02	≤0.02	≤0.02	≤0.02	≤0.02
16.0	≤0.02	≤0.02	≤0.02	≤0.02	≤0.02
20.0	-	≤0.02	≤0.02	-	≤0.02
25.0	-	≤0.02	≤0.02	-	≤0.02
32.0	-	≤0.02	≤0.02	-	≤0.02

[†]Auxiliary for the 2-pole will be configured: N/C for 1st pole & N/O for 2nd pole.
Auxiliary for the 3-pole will be configured: N/C for 1st pole & N/O for 3rd pole.

*Standard breakers will be calibrated to a M1 trip curve with N/O Auxiliary Contacts.

CB2200 Series Supplemental Circuit Breakers

CB2200 Series

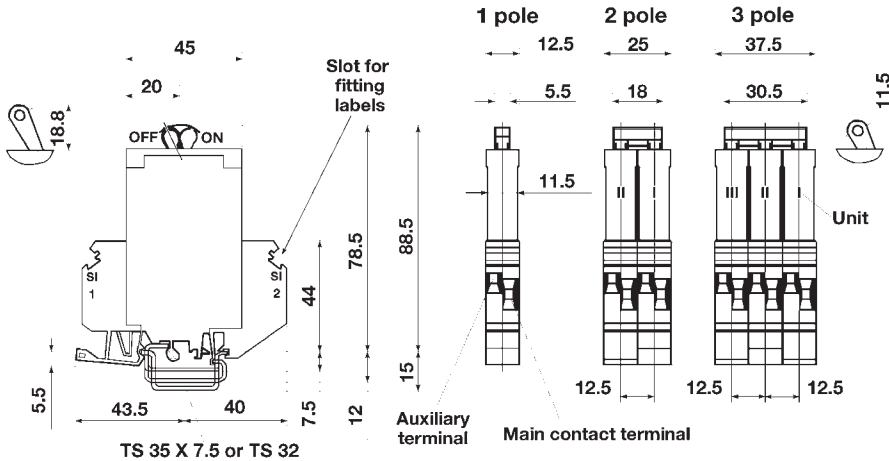

Dimensions in mm

Internal Wiring Diagram

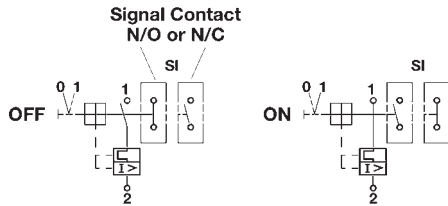

Note:
N/O-Auxiliary contact will be open during normal state. Aux. will close when breaker trips.

N/C-Auxiliary contact will be closed during normal state. Aux. will open when breaker trips.

Technical Data

Rated voltage & current†	UL
	CSA
	VDE
Auxiliary contacts	
Creepage resistance	
Dielectric strength	
Insulation resistance	
Interrupting capacity (VDE 0660, Part 101, P-2)	
Interrupting capacity (UL 1077/EN 60934 PC1)	
Typical life at 2 x rated current	
Shock	
Torque	Nm (lb. in.)
Vibration	
Temperature range	
Corrosion	
Humidity	
Weight	
Wire size (UL)	

Voltage Ratings		Current Ratings
277 / 480 VAC (50/60 Hz); 65 VDC		0.1...32 A
277 / 480 VAC (50/60 Hz); 65 VDC		0.1...32 A
250 / 415 VAC / 65 VDC		0.1...32 A
250 VAC / 65 VDC, 1 A		
PTI 600 to IEC 112		
3,000 VAC; IEC 664 & 664 A		
> 100 MΩ (DC 500 V)		
Rated current	Rated voltage	Rupture capacity (3 times)
0.05...0.8 A	250 / 415 VAC	400 A
6...32 A	250 / 415 VAC	800 A
Rated current	Rated voltage	Max. rupture capacity (3 times)
0.1...16 A	277 / 480 VAC	5000 A
20...32 A	277 / 480 VAC	2000 A
0.1...32 A	65 VDC	2000 A
5,000 operations		
25 g (11 ms) to IEC 68-2-27, Test Ea		
0.6 (5.3) Auxiliary contact: 0.5 (4.4)		
5 g (57 to 500 Hz / ±0.38 mm, 10 to 57 Hz) to IEC 68-2-6, Test Fc		
-30...+60°C (-22°F...+140°F)		
96 hours at 5% salt spray, to IEC 68-2-11, Test Ka		
240 hours at 95% RH, to IEC 68-2-3, Test Ca		
Approximately 60 g per pole		
max 6 mm²...8 AWG max 1.5 mm²...14 AWG (Aux. contact)		

Accessories

Jumpers	Daisy Chain 50
---------	----------------

Marking Tags

Special print only	DEK 5/6	0490360000*
Consecutive horizontal	DEK 5/6	0468660001
Consecutive vertical	DEK 5/6	0468760001

Note: Part numbers shown are for a single card of pre-printed tags numbered 1-50.

†Note: Resistive and inductive loads (0.05 - 16 A)
*Please specify horizontal or vertical print when ordering.

Trip Curves—Thermal Magnetic Type Typical time/current characteristics at 23°C

CB2200 Series

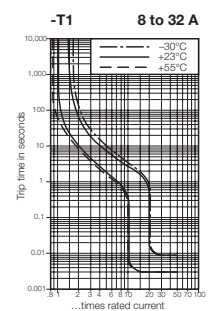
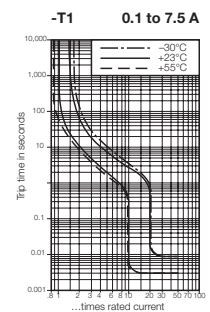
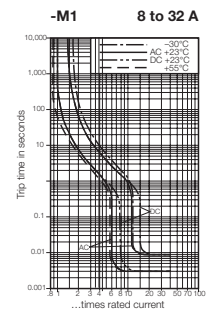
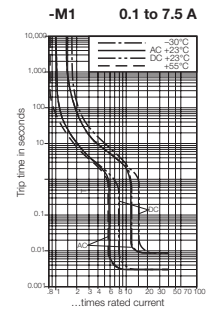
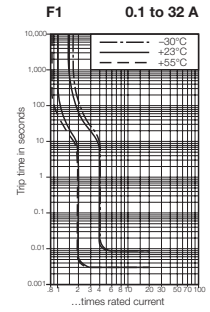

CB9100 Series Supplemental Circuit Breakers

Circuit Breakers Thermal Magnetic Type

- Rated from 0.5 to 63 amps
- Available in single, double and triple pole configurations
- Optional auxiliary contacts
- Mounts on 35mm DIN-rail
- UL and CSA approvals
- CSA 277 VAC (1 pole) or 480 VAC (2 and 3 pole)
- 50 VDC (0.5 A to 50 A) 1 pole
- 110 VDC (0.5 A to 50 A) 2 pole

CB9100 Series Single Pole



CB9100 Series Double Pole



CB9100 Series Triple Pole



Ordering Data	
Internal Resistance per Pole (ohms)	
6.2	
1.7	
0.45	
0.22	
0.125	
0.05	
<0.02	
<0.02	
<0.02	
<0.02	
<0.02	
<0.02	
<0.02	
<0.02	
<0.02	
<0.02	
<0.02	

Type: Single Pole	
Current Ratings (amps)	Part No.
0.5	9925350000
1.0	9925360000
2.0	9925380000
3.0	9925390000
4.0	9925400000
6.0	9925410000
10.0	9925430000
13.0	9929820000
16	9925440000
20	9925450000
25	9925460000
32	9925470000
40	9925480000
50	9925490000
63	9925500000

Type: Double Pole	
Current Ratings (amps)	Part No.
0.5	9925650000
1.0	9925660000
2.0	9925680000
3.0	9925690000
4.0	9925700000
6.0	9925710000
10.0	9925730000
13.0	9929830000
16	9925740000
20	9925750000
25	9925760000
32	9925770000
40	9925780000
50	9925790000
63	9925800000

Type: Triple Pole	
Current Ratings (amps)	Part No.
0.5	9925810000
1.0	9925820000
2.0	9925840000
3.0	9925850000
4.0	9925860000
6.0	9925870000
10.0	9925890000
13.0	9929840000
16	9925900000
20	9925910000
25	9925920000
32	9925930000
40	9925940000
50	9925950000
63	9925960000

Trip Curves Thermal Magnetic Type Typical time/current characteristics at 23°C

CB9100 Series

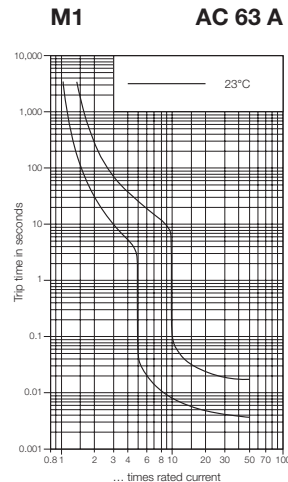
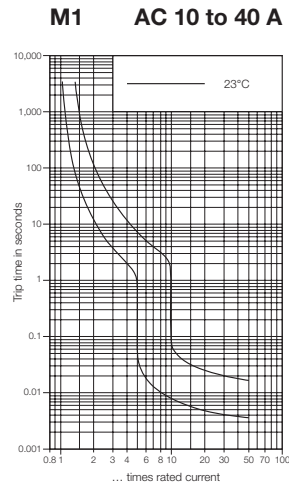
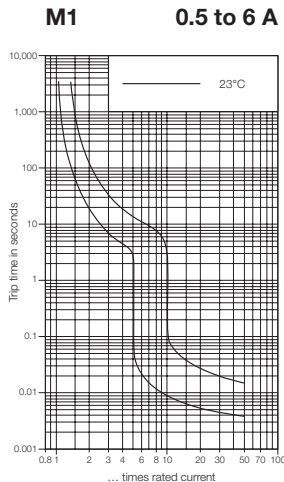

Note: "C" trip time characteristics according to VDE 064 A4/11.88 (9100 Series only)

CB9100 Series Supplemental Circuit Breakers

CB9100 Series

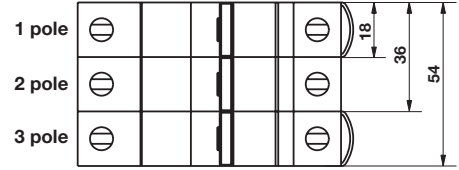
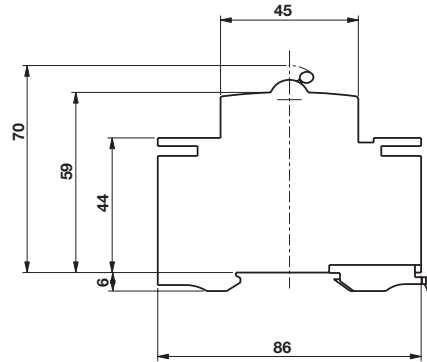

Dimensions in mm

Internal Wiring Diagram

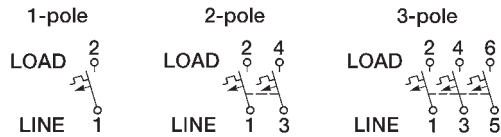

Technical Data

Rated voltage & current

UL 1077

CSA C 22.2 No. 235

Creepage resistance

Insulation resistance

Interrupting capacity

(UL 1077/EN 609334 PC1) 1 pole

Mechanical/Electrical endurance

Shock

Torque

Vibration

Temperature range - operating

Weight

Strip length

Auxiliary contact rating

Wire size - #22...12 AWG

Wire size

Accessories

Jumpers

Auxiliary contacts

SPDT

Security hardware

Marking Tags

Adhesive label

277 V (1 pole) 480 V (2 and 3 pole) 50 VDC (1 pole) 110 VDC (2 pole)

277 V (1 pole) 480 V (2 and 3 pole) 50 VDC (1 pole) 110 VDC (2 pole)

PTI 250 to IEC 112

>100 MΩ at 500 VDC

Current ratings

Interrupting Rupture capacity (3X)

Voltage

0.5...63 A

10,000 A (UL)

277 VAC/50 VDC

0.5...32 A

2,000 A (UL)

347 / 600 AC

0.5...63 A

6,000 A (UL)

50 VDC (1) pole

0.5...50 A

6,000 A (UL)

110 VDC (2) poles

20,000/10,000

20 g (10 ms)

2 Nm

3 g (10 to 55 Hz)

-25°C...+55°C (-13°F to 131°F)

1 pole (130 g); 2 pole (280 g); 3 pole (430 g)

12 mm

Voltage

Current

AC 220/240

5 A

AC 277

3 A

DC 24 V

4 A

DC 60 V

1 A

DC220 V

0.4 A

#18...2 AWG (line); #18...3 AWG (load)

Type

Part No.

3 pole bus, 10 x 1010 mm, buses (19) 3 phase groupings

9970330000

3 pole bus, 16 x 210 mm, buses (4) 3 phase groupings

9970340000

3 pole bus, 16 x 1010 mm, buses (19) 3 phase groupings

9970350000

1 pole bus, 12 x 210 mm, buses 12 breakers

9970360000

1 pole bus, 12 x 210 mm (insulated), buses 12 breakers

9991990000

Bus bar clamp

9970370000

Auxiliary contacts

9970300000

Lock out cover

9970380000

Auxiliary Contact Modules

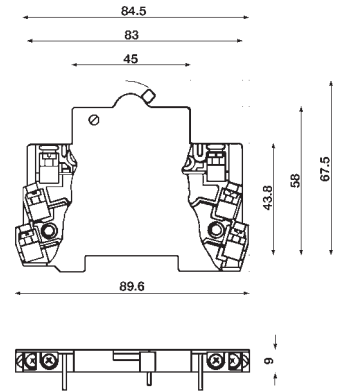

Note:

N/O-Auxiliary contact will be open during normal state. Aux. will close when breaker trips.

N/C-Auxiliary contact will be closed during normal state. Aux. will open when breaker trips.

Internal Auxiliary Wiring Diagram

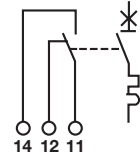

Note:

N/O-Auxiliary contact will be open during normal state. Aux. will close when breaker trips.

N/C-Auxiliary contact will be closed during normal state. Aux. will open when breaker trips.

Argentina
Australia
Austria
Azerbaijan
Bahrain
Belarus
Belgium
Bosnia-
Herzegovina
Brazil
Bulgaria
Canada
Chile
China
Colombia
Costa Rica
Croatia
Czech Republic
Denmark
Ecuador
Egypt
Estonia
Finland
France
Germany
Greece
Hong Kong
Hungary
Iceland
India
Indonesia

Iran
Ireland
Israel
Italy
Japan
Jordan
Kazakhstan
Kuwait
Latvia
Lebanon
Lithuania
Luxembourg
Macedonia
Malaysia
Malta
Mexico
Montenegro
Netherlands
New Zealand
Norway
Oman
Paraguay
Peru
Philippines
Poland
Portugal
Qatar
Romania
Russia
Saudi Arabia
Serbia

Singapore
Slovakia
Slovenia
South Africa
South Korea
Spain
Sweden
Switzerland
Syria
Taiwan
Thailand
Turkey
UAE
Ukraine
United Kingdom
Uruguay
USA
Venezuela
Vietnam
Yemen

Weidmuller is the leading manufacturer of components for electrical connection technology to transmit energy, signals and data. The Weidmuller product portfolio ranges from terminal blocks, PCB connectors and terminals, protected components, Industrial Ethernet components, I/O components and relay sockets to power supplies and overvoltage protection modules suitable for all applications. Assemble Services, marking solutions with a variety of tools and software systems, round off the range. As an OEM supplier, the company sets global standards in the field of electrical connection technology.

Weidmuller, Canada
10 Spy Court
Markham, Ontario L3R 5H6
Telephone: (800) 268-4080
Facsimile: (905) 475-2798
Email: info1@weidmuller.ca
Website: www.weidmuller.ca

Weidmuller, Mexico
Blvd. Hernamos Serdán 698,
Col. San Rafael Oriente Puebla,
Puebla, C.P. 72029, Mexico
Telephone: 01 222 2686227
Facsimile: 01 222 2686219
Email: clientes@weidmuller.com.mx
Website: www.weidmuller.com.mx

Weidmuller, United States
821 Southlake Blvd.
Richmond, Virginia 23236
Telephone: (800) 849-9343
Facsimile: (804) 379-2593
Email: info@weidmuller.com
Website: www.weidmuller.com